

OVERVIEW

The LC-081 or Layad Circuits' Serial Temperature Scanner is a UART ("Serial") interfaceable non-contact thermal reader. The device is designed to be used with a larger system with a any UART/Serial-capable host microcontroller such as Arduino or Raspebry Pi. It comes with all the necessary electronics to perform temperature scanning of people or objects and output the reading into its seven segment display and UART port via the attached female pinheader-terminated wires. The LC-081 comes in 3 distinct Modes and can use either Fahrenheit and Celsius as its unit of measurement.



The device aims to replace sensor-module solutions (e.g. MLX90614) by improving upon the issues accompanying such sensor-only implementation including the need for a separate proximity sensor, display, power regulator, level shifter, buzzer, enclosure, warning LEDs, and audio notification. It also simplifies use for human body temperature measurements as the device is pre-calibrated for such. Finally, the difficulties associated with I2C implementation such as bus sharing issues or the need to for an external library are eliminated.

NOTE: This device is meant for educational purposes only (e.g. product prototypes) and does not replace medical or industrial grade thermometers.

www.layadcircuits.com

Layad Circuits Electronics Engineering Supplies & Services, B314 Lopez Bldg., Session Rd. cor. Assumption Rd., Baguio City, Philippines
General inquiries: info@layadcircuits.com Sales: sales@layadcircuits.com FB: facebook.com/layadcircuits Mobile: +639164428565

An IMPORTANT NOTICE: at the end of this guide addresses availability, warranty, changes, use in safety-critical applications, intellectual property matters and other important disclaimers.

FEATURES

- Ready interface port for microcontrollers via UART serial interface.
 - 9600 baud rate, 8 data bits, no parity, and 1 stop bit
 - Simple serial text protocol
 - TX only at 3.3V logic
- Modes
 - Body Mode
 - Surface Mode
 - Counting Mode
- 2 Units of measurement
 - Celsius
 - Fahrenheit
- Automatic Alarm for "high" readings
- Accuracy : ± 0.2 degrees
- Measurement Distance: $\sim 5-10$ cm
- Input power: 5V
- Typical Power Consumption: < 200 mA
- Peak Power Consumption: < 450 mA
- Integrated casing, LCD readout and buttons
- Works with both 5V and 3.3V logic
- Response Time: ~ 0.5 sec
- Arduino, Raspberry Pi, ESP8266, ESP32 compatible

PIN FUNCTIONS

There are two sets of color codes for the wired header port of the device. Your unit should come in either one of them. Refer to the tables below.

Code 1: Brown-Red-Orange

Wire Color	Function
Brown	GND: (-) Ground
Red	VCC: (+) 5Vdc power
Orange	TXD: Serial Transmit Pin. Connect to the serial receive pin of the host MCU.

Code 2: Black-White-Gray

Wire Color	Function
Black	GND: (-) Ground
White	VCC: (+) 5Vdc power
Gray	TXD: Serial Transmit Pin. Connect to the serial receive pin of the host MCU.

Copyright 2022 © Layad Circuits All Rights Reserved

UART/ SERIAL PORT

The Device has no RXD terminal as it only outputs data on its TXD terminal/pin. Although the power required is 5V, the TXD signal is at 3.3V logic, therefore, it may be used directly with 5V logic host controller (e.g. Arduino Uno, Mega, Nano) or with a 3.3V host such as Raspberry Pi, ESP8266 or ESP32 without the need for a level shifter circuit. The baud rate is 9600 at the standard configuration of 8 data bits, no parity and 1 stop bit.

POWER REQUIREMENTS

The unit should be powered from a regulated 5V power source that can reliably deliver current of up to 450mA.

Powering at the Wired Terminal

The LC-081 maybe powered from the 5V pin of most Arduino board as these are typically rated at 1A. However, care should be exercised when there are other electrical loads being supplied by the Arduino regulator or if the device is to be used in the long term. We recommend using a separate 5V regulator circuit that can supply $\geq 500\text{mA}$ such as an LM7805 with heatsink or a buck converter module such as LM2596. Refer to the current consumption table below:

Device State	Current Consumption
Idle state	190mA \pm 100mA
Peak current while in active operation	<450mA

Powering at the USB port

A microUSB port is also available as power source. Please check that your microUSB power supply has a 5V output. Some smart power supplies may output more than 5V and should therefore not be used with this device.

Warning: When the microUSB port is powered, do not connect the VCC wire to another 5V power source. Only the TXD and GND should be connected to the host microcontroller in this case.

www.layadcircuits.com

Layad Circuits Electronics Engineering Supplies & Services, B314 Lopez Bldg., Session Rd. cor. Assumption Rd., Baguio City, Philippines
 General inquiries: info@layadcircuits.com Sales: sales@layadcircuits.com FB: [facebook.com/layadcircuits](https://www.facebook.com/layadcircuits) Mobile: +639164428565

An IMPORTANT NOTICE: at the end of this guide addresses availability, warranty, changes, use in safety-critical applications, intellectual property matters and other important disclaimers.

While the casing has a battery slot, it has no use. The device is designed to be powered at the wired terminals. Any battery implementation should consider powering the whole system, including the host microcontroller.

SIZE VARIANTS

The device comes in 2 sizes, the “large” and the “small” variant. Please contact Layad Circuits for additional information.

USER BUTTONS AND POWER SWITCH

The user buttons and their functions are described in the table below.

Large Variant

ON/OFF Switch	Control this witch to turn the power on and off
Mode/Unit Button	Short presses will switch the units between °C and °F, and long press to change modes between Body, Surface, and Counting modes.

Small Variant

ON/OFF Button	Press once to turn ON and long press to power OFF the device
Mode/Unit Button	Short presses will switch the units between °C and °F, and long press to change modes between Body, Surface, and Counting modes.

MODES

The LC-081 has 3 Modes that serves different purposes as described below:

1. Body (B) Mode

This mode is designed for scanning human body temperature. It is the primary purpose of this device and has a range of 32-42 °C or 89.6-107.6 °F. It has an alarm function where readings that reach 37.5-42 °C or 99.5- 107.6 °F (default setting) will generate an alarm by flashing the front red lights continuously for 5 seconds.

Copyright 2022 © Layad Circuits All Rights Reserved

The scanner will be disabled within that 5 second. A voice alarm is also generated.

bod

When Body mode is set, the format of the output serial data is as follows:

@,<Temperature>,<Unit>,<Mode>,<CR><LF>

Where:

- Temperature – the temperature reading in 3 whole digits and 1 decimal digit
- Unit – either 'C' (0x43) for Celsius or 'F' (0x46) for Fahrenheit
- Mode – 'B' (0x42) for body mode
- CR – carriage return character (0x0D)
- LF – line feed / new line character (0x0A)

Examples:

@,036.5,C,B,#

@,097.7,F,B,#

2. Surface (S) Mode

This mode is designed to measure temperature of objects thus having a much wider range. It has a tested coverage of 0.3- 99.8 °C or 32.5-212.4 °F.

Sur

When Surface mode is set, the format of the output serial data is as follows:

@,<Temperature>,<Unit>,<Mode>,<CR><LF>

Where:

- Temperature – the temperature reading in 3 whole digits and 1 decimal digit
- Unit – either 'C' (0x43) for Celsius or 'F' (0x46) for Fahrenheit
- Mode – any of the following: 'S' (0x53) for surface mode

- CR – carriage return character (0x0D)
- LF – line feed / new line character (0x0A)

Examples:

@,025.4,C,B,#

@,077.7,F,B,#

3. Counting (C) Mode

In this mode, the Serial Temperature Scanner act as a person/object counter. It will count and beep each time someone or something was detected within its proximity. Be noted that changing the mode or power cycling will reset the counter.

Count

When Counting mode is set, the format of the output serial data is as follows:

@,<Count>,<Unit>,<Mode>,<CR><LF>

Where:

- Count – 5 digit count
- Unit – 'N' (0x4E) for no unit
- Mode – 'C' (0x43) for counting mode
- CR – carriage return character (0x0D)
- LF – line feed / new line character (0x0A)

Example:

@,00001,N,C,#

ALARMS

When HI or Lo is displayed in the front panel accompanied by a flash of red lights, this indicates that the measurement is out of range.

HI

The measured temperature is higher than the specified range of 42 °C/107.6 °F for Body and 99.8 °C /212.4 °F for Surface.

Lo

The measured temperature falls below the specified range of 32°C/89.6 °F for Body and 0.3°C/32.5 °F for Surface.

The serial output date will show an Error code shown below:

@,00000,0,0,# <CR><LF>

Where:

- @,00000,0,0,# - this is the error code
- CR – carriage return character (0x0D)
- LF – line feed / new line character (0x0A)

Example:

@,00000,0,0,#

FACTORY RESET

Press and hold the power button for 6 secs until **rST** is displayed. It will reset the High Temperature Setting and Low temperature Setting to the default settings.

SETTINGS MENU

A series of settings may be adjusted by accessing the settings menu. **We do not recommend changing any of these.** However, we are enumerating them in this section for reference. Note that specific variants may omit certain settings.

To access the menu, follow the procedure below:

Large Variant:

- Turn the power off
- Press and hold the mode button

LC-081 SERIAL TEMPERATURE SCANNER User Guide

- Turn on the power while the button is still pressed
- The firmware version momentarily displays on the front panel. At this point release the button
- The display will then show the dots lighting up in sequence. At this point press and hold the button again to enter the menu

Small Variant:

- Press and hold both power button and mode button to enter the settings menu.

A sequence of settings will be presented to the user after entering the menu.

- To change value/setting of each menu – short press the buttons
- To save the current selected value/setting - press and hold both buttons for small variant or the mode button for large variant. The next setting is automatically presented.

The settings are as follows. Not all settings may appear on a particular variant.

1. High Temperature Alarm Setting

This sets the temperature at which the High Temperature Alarm, e.g. temperature considered as fever. The default is 37.5 Celsius.

2. Low temperature Setting

This setting has 2 options, **Lo/nor** and **32.0**. It is recommended to keep this setting in the Lo/nor option.

- **LO** or **nor** – when temperature measured is 32.0 °C or lower, an alarm is generated and the “Lo” is displayed on the front panel. This indicates that the measurement is out of range and should be repeated. The serial data shall send out the error code (refer to MODES section). This is the default setting. “LO” and “nor” are the same.
- **32.0** – In this option, the device will attempt to output whatever is measured out into the serial

www.layadcircuits.com

Layad Circuits Electronics Engineering Supplies & Services, B314 Lopez Bldg., Session Rd. cor. Assumption Rd., Baguio City, Philippines
General inquiries: info@layadcircuits.com Sales: sales@layadcircuits.com FB: [facebook.com/layadcircuits](https://www.facebook.com/layadcircuits) Mobile: +639164428565

An IMPORTANT NOTICE: at the end of this guide addresses availability, warranty, changes, use in safety-critical applications, intellectual property matters and other important disclaimers.

Copyright 2022 © Layad Circuits All Rights Reserved

port regardless if this is out of the body mode temperature range. The display on the front panel shall remain as 32.0 and no alarm is generated.

3. Language setting - Selects between Chinese (CH), English (EN), Italian (IT), Korean (HR), Spanish (SP) and other languages. The default is English (EN).

4. Volume setting:

Select Vo0 to Vo5 volume level. Vo5 is the highest and Vo0 is silent. The default is Vo2

5. Buzzer Setting

Choose between a short beep (d1) and a doorbell tone (d0) on every detected proximity. The default is d1

6. S-setting

Do not change this parameter. This is a reserved setting.

7. Automatic Shutdown

In A1 option, the device will automatically shutdown if no operation is performed in 12 hours. Power cycle or long press the power button to wake the device up. A0 option disables this feature and keeps the device awake indefinitely.

8. Firmware

Display the firmware version number

9. Menu Exit

After switching to the version number, long press the two buttons for the small variant, or the mode button for the large variant, to exit the settings menu. The device will automatically exit if no operation is detected within 10 seconds.

DEVICE LAYOUT

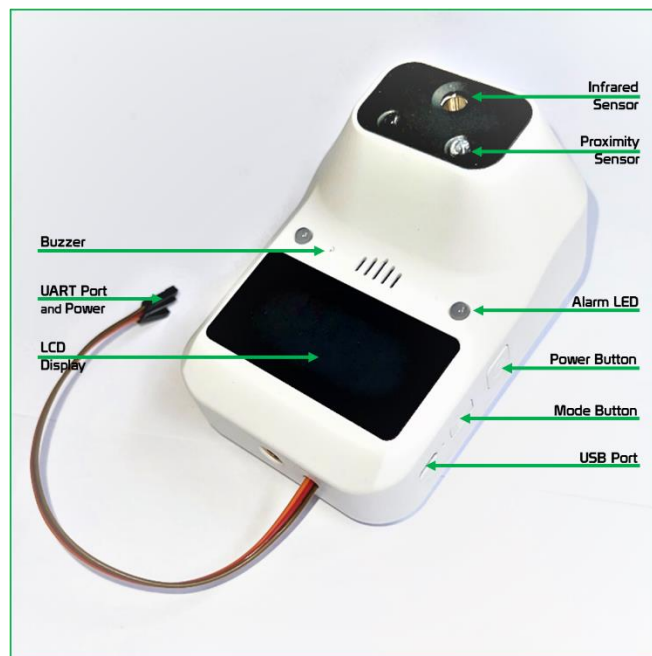

SPECIFICATION

Product Code	LC-081
Product Name	Serial Temperature Scanner
Display	Seven Segment
Accuracy	±0.2 degrees
Response Time	0.5s
High Temperature Alarm Setting	37.5-42 Celsius (Default)
Measuring Distance	5-10cm
Input Voltage Power	5V
Typical Current	<200mA
Peak Current	<450mA
Infrared Measuring Range	0-50 Celsius
Weight	<160g : small unit <230g : large unit

APPLICATION NOTES

EXAMPLE WIRING: LC-081 TO ARDUINO UNO

In this diagram, the LC-081 is connected to an Arduino UNO using SoftwareSerial with RXD define at pin 2 and TXD defined at pin 3. Although we are declaring pin 3 as the TXD of the Arduino, we do not need it for the LC-081.

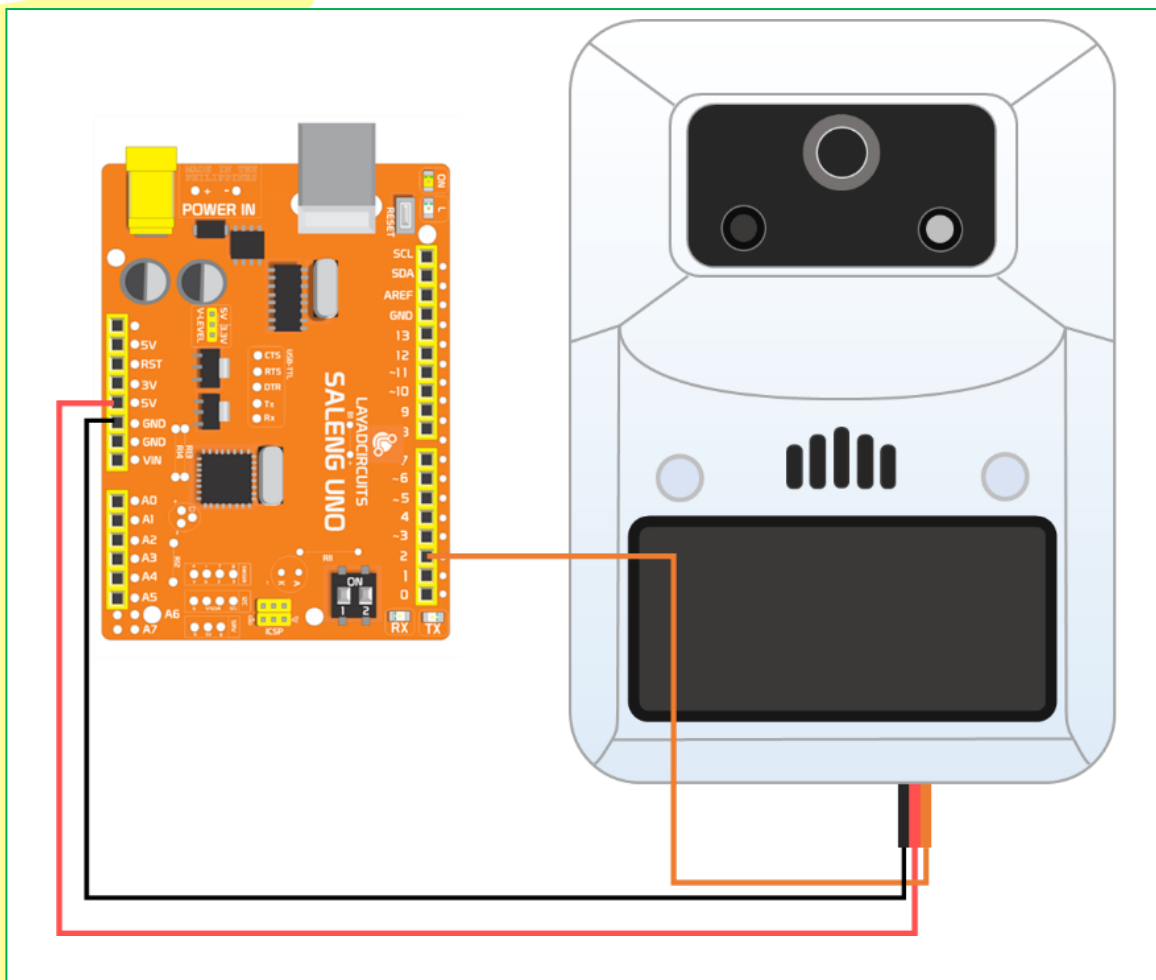

EXAMPLE CODE #1

This is a simple code used to print the **raw** data received from the LC-081 into the Arduino Uno's hardware serial port and viewed from the Serial Monitor set to 9600 baud rate. Wiring follows the previous diagram.

```
#include <SoftwareSerial.h>
SoftwareSerial IRscanner(2,3); //RX, TX

void setup()
{
  Serial.begin(9600); // serial monitor port
  IRscanner.begin(9600); //LC-081 serial port
}

void loop()
{
  while (IRscanner.available()>0)
  {
    Serial.write(IRscanner.read());
  }
}
```

EXAMPLE CODE #2

www.layadcircuits.com

Copyright 2022 © Layad Circuits All Rights Reserved

Layad Circuits Electronics Engineering Supplies & Services, B314 Lopez Bldg., Session Rd. cor. Assumption Rd., Baguio City, Philippines

General inquiries: info@layadcircuits.com Sales: sales@layadcircuits.com FB: facebook.com/layadcircuits Mobile: +639164428565

An IMPORTANT NOTICE: at the end of this guide addresses availability, warranty, changes, use in safety-critical applications, intellectual property matters and other important disclaimers.

This code stores the data received from the thermal scanner and converts it into a float variable. Wiring follows the previous diagram.

```
#include <SoftwareSerial.h>
SoftwareSerial IRscanner(2, 3); // RX, TX
float temperature;

void setup()
{
  Serial.begin(9600);           //arduino serial port
  IRscanner.begin(9600);       //IR scanner serial port
}

void loop()
{
  while (IRscanner.available()>0)
  {
    static char IRreading[14];
    static unsigned int reading_position=0;
    char store=IRscanner.read(); //store data received as a whole

    if( store!='\n' && reading_position<13 )
    {
      IRreading[reading_position]=store; //store the whole data as an array
      reading_position++;
    }
    else
    {
      //print temperature
      static char store_number[6]="";
      memcpy(store_number,&IRreading[2],5); //store only the numbers into an array
      temperature = atof(store_number); //convert the numbers received as float
      Serial.print(temperature,1); //print with 1 decimal digit

      //print unit
      if(IRreading[8]=='C'){ Serial.print(" Celsius, "); }
      else if(IRreading[8]=='F'){ Serial.print(" Fahrenheit, "); }
      else{Serial.print(" no unit, ");}

      //print mode
      if(IRreading[10]=='B'){ Serial.println("BODY"); }
      else if(IRreading[10]=='S'){ Serial.println("SURFACE"); }
      else if(IRreading[10]=='C'){ Serial.println("COUNTING"); }
      else{Serial.println("ERROR");}

      reading_position=0; //reset for next message
      while (IRscanner.available()) { IRscanner.read(); } //clear serial buffer
    }
  }
}
```

DIRECT TO COMPUTER / RASPBERRY PI

If the device is to be used with a computer as its controller, then a simple UART-to-USB converter module or dongle may be used. Below is an example using the Kimat USB-TTL converter dongle. Other dongles may be used such as those based around FTDI, Prolific or CH340x chips.

Although a Raspberry Pi board has raw UART pins at its GPIO headers where we can interface the LC-081 directly, there may be use cases where a USB connection is necessary or desirable. In such case, the same UART-to-USB converter circuit is required.

In both cases above, the driver software of the converter chip drivers must be installed into the host computer/Raspberry Pi.

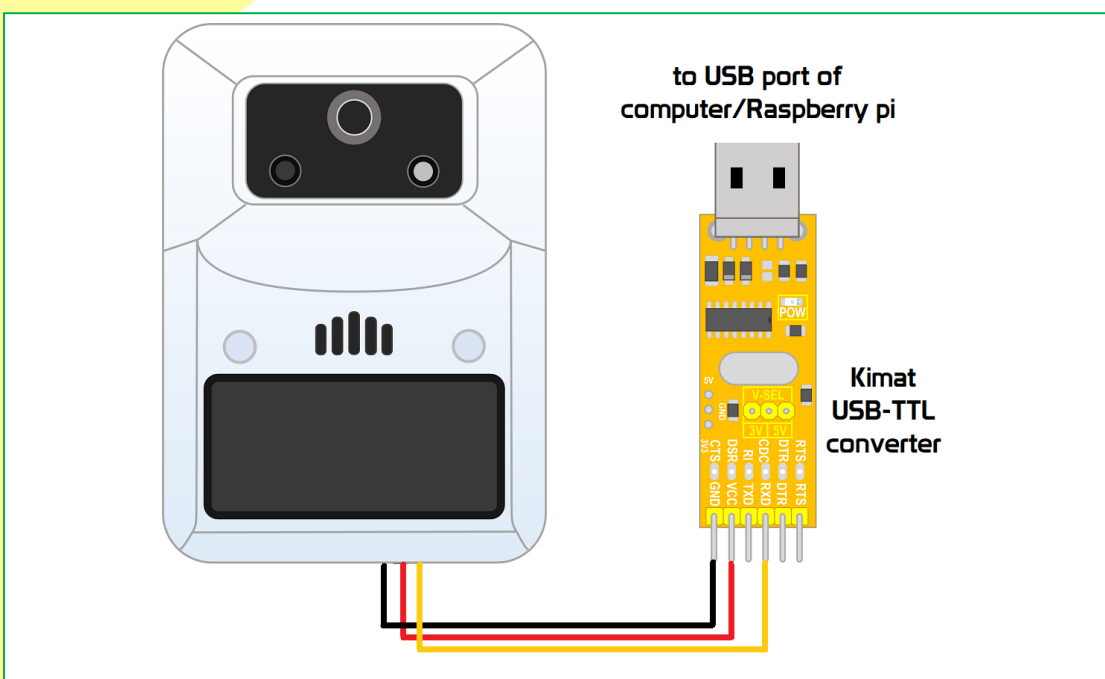

Once connected the data can be read out of the serial port (COMx in Windows) set at a baud rate of 9600, 8 databits, No parity and 1 stop bit. Program the application software to receive this data and process or present it accordingly. This computer/Raspberry Pi application is beyond the scope of this document.

TROUBLESHOOTING

Symptom / Problem	Fix / Solution
Seven Segment Display is Dim	Use an appropriate power supply that can output a regulated 5V and at least 450mA of current
“Running dots” is relaced with “running dashes”	Use an appropriate power supply that can output a regulated 5V and at least 450mA of current
No output data or random output data	Ensure that the receiving device / application has its port set to 9600 baud rate.

DOCUMENT REVISION

v1.00 – 09 Aug 2022 / C.D.Malecdan , K.D.Acosta – initial version

** this is an evolving document **

www.layadcircuits.com

Copyright 2022 © Layad Circuits All Rights Reserved
Layad Circuits Electronics Engineering Supplies & Services, B314 Lopez Bldg., Session Rd. cor. Assumption Rd., Baguio City, Philippines
General inquiries: info@layadcircuits.com Sales: sales@layadcircuits.com FB: facebook.com/layadcircuits Mobile: +639164428565

An IMPORTANT NOTICE: at the end of this guide addresses availability, warranty, changes, use in safety-critical applications, intellectual property matters and other important disclaimers.

IMPORTANT NOTICE

Layad Circuits Electronics Engineering Supplies & Services (Layad Circuits) reserves the right to make corrections, enhancements, improvements and other changes to its products, services and documentations, and to discontinue any product or service. Buyers or clients should obtain the latest relevant information before placing orders and should verify that such information is current and complete. Additional terms may apply to the use or sale of Layad Circuits products and services.

Reproduction of significant portions of Layad Circuits information in Layad Circuits datasheets or user guides is permissible only if reproduction is without alteration, displays the Layad Circuits logo and is accompanied by all associated warranties, conditions, limitations, and notices. Layad Circuits is not responsible or liable for such reproduced documentation. Information of third parties may be subject to additional restrictions. Resale of Layad Circuits products or services with statements different from or beyond the parameters stated by Layad Circuits for that product or service voids all express and any implied warranties for the associated Layad Circuits product or service. Layad Circuits is not responsible or liable for any such statements.

Buyers and others who are developing systems that incorporate Layad Circuits products (collectively, "Designers") understand and agree that Designers remain responsible for using their independent analysis, evaluation and judgment in designing their applications and that Designers have full and exclusive responsibility to assure the safety of Designers' applications and compliance of their applications (and of all Layad Circuits products used in or for Designers' applications) with all applicable regulations, laws and other applicable requirements. Designer represents that, with respect to their applications, Designer has all the necessary expertise to create and implement safeguards that (1) anticipate dangerous consequences of failures, (2) monitor failures and their consequences, and (3) lessen the likelihood of failures that might cause harm and take appropriate actions. Designer agrees that prior to using or distributing any applications that include Layad Circuits products, Designer will thoroughly test such applications and the functionality of such Layad Circuits products as used in such applications. Layad Circuits' provision of technical, application or other design advice, quality characterization, reliability data or other services or information, including, but not limited to, reference designs and materials relating to evaluation modules, (collectively, "Layad Circuits Resources") are intended to assist designers who are developing applications that incorporate Layad Circuits products; by downloading, accessing or using Layad Circuits Resources in any way, Designer (individually or, if Designer is acting on behalf of a company, Designer's company) agrees to use any particular Layad Circuits Resource solely for this purpose and subject to the terms of this Notice.

Layad Circuits' provision of Layad Circuits Resources does not expand or otherwise alter Layad Circuits' applicable published warranties or warranty disclaimers for Layad Circuits products, and no additional obligations or liabilities arise from Layad Circuits providing such Layad Circuits Resources.

Layad Circuits reserves the right to make corrections, enhancements, improvements and other changes to its Layad Circuits Resources. Layad Circuits has not conducted any testing other than that specifically described in the published documentation for a particular Layad Circuits Resource.

NO OTHER LICENSE, EXPRESS OR IMPLIED, BY ESTOPPEL OR OTHERWISE TO ANY OTHER LAYAD CIRCUITS INTELLECTUAL PROPERTY RIGHT, AND NO LICENSE TO ANY TECHNOLOGY OR INTELLECTUAL PROPERTY RIGHT OF LAYAD CIRCUITS OR ANY THIRD PARTY IS GRANTED HEREIN, including but not limited to any patent right, copyright, mask work right, or other intellectual property right relating to any combination, machine, or process in which Layad Circuits products or services are used. Information regarding or referencing third-party products or services does not constitute a license to use such products or services, or a warranty or endorsement thereof. Use of Layad Circuits Resources may require a license from a third party under the patents or other intellectual property of the third party, or a license from Layad Circuits under the patents or other intellectual property of Layad Circuits. LAYAD CIRCUITS RESOURCES ARE PROVIDED "AS IS" AND WITH ALL FAULTS. LAYAD CIRCUITS DISCLAIMS ALL OTHER WARRANTIES OR REPRESENTATIONS, EXPRESS OR IMPLIED, REGARDING RESOURCES OR USE THEREOF, INCLUDING BUT NOT LIMITED TO ACCURACY OR COMPLETENESS, TITLE, ANY EPIDEMIC FAILURE WARRANTY AND ANY IMPLIED WARRANTIES OF MERCHANTABILITY, FITNESS FOR A PARTICULAR PURPOSE, AND NON-INFRINGEMENT OF ANY THIRD PARTY INTELLECTUAL PROPERTY RIGHTS. LAYAD CIRCUITS SHALL NOT BE LIABLE FOR AND SHALL NOT DEFEND OR INDEMNIFY DESIGNER AGAINST ANY CLAIM, INCLUDING BUT NOT LIMITED TO ANY INFRINGEMENT CLAIM THAT RELATES TO OR IS BASED ON ANY COMBINATION OF PRODUCTS EVEN IF DESCRIBED IN LAYAD CIRCUITS RESOURCES OR OTHERWISE. IN NO EVENT SHALL LAYAD CIRCUITS BE LIABLE FOR ANY ACTUAL, DIRECT, SPECIAL, COLLATERAL, INDIRECT, PUNITIVE, INCIDENTAL, CONSEQUENTIAL OR EXEMPLARY DAMAGES IN CONNECTION WITH OR ARISING OUT OF LAYAD CIRCUITS RESOURCES OR USE THEREOF, AND REGARDLESS OF WHETHER LAYAD CIRCUITS HAS BEEN ADVISED OF THE POSSIBILITY OF SUCH DAMAGES. Unless Layad Circuits has explicitly designated an individual product as meeting the requirements of a particular industry standard, Layad Circuits is not responsible for any failure to meet such industry standard requirements. Where Layad Circuits specifically promotes products as facilitating functional safety or as compliant with industry functional safety standards, such products are intended to help enable customers to design and create their own applications that meet applicable functional safety standards and requirements. Using products in an application does not by itself establish any safety features in the application. Designers must ensure compliance with safety-related requirements and standards applicable to their applications. Designer may NOT use any Layad Circuits products in life-critical applications. Life-critical medical equipment is medical equipment where failure of such equipment would cause serious bodily injury or death (e.g., life support, pacemakers, defibrillators, heart pumps, neurostimulators, and implantables). Designers agree that it has the necessary expertise to select the product with the appropriate qualification designation for their applications and that proper product selection is at Designers' own risk. Designers are solely responsible for compliance with all legal and regulatory requirements in connection with such selection. Designer will fully indemnify Layad Circuits and its representatives against any damages, costs, losses, and/or liabilities arising out of Designer's noncompliance with the terms and provisions of this Notice.

www.layadcircuits.com

Layad Circuits Electronics Engineering Supplies & Services, B314 Lopez Bldg., Session Rd. cor. Assumption Rd., Baguio City, Philippines
General inquiries: info@layadcircuits.com Sales: sales@layadcircuits.com FB: facebook.com/layadcircuits Mobile: +639164428565

An IMPORTANT NOTICE: at the end of this guide addresses availability, warranty, changes, use in safety-critical applications, intellectual property matters and other important disclaimers.

