

OVERVIEW

The PS/2 Keyboard Interface module allows the user to connect a PS/2 keyboard (or mouse) to an Arduino or other microcontrollers. The module facilitates connection by integrating a PS/2 port with standard header pins for power and data lines. The PS/2 port is a 6-pin mini-DIN connector. When connected to a keyboard, alphanumeric characters may then be read by the host microcontroller.



Figure 1 PS2 Port

See the applications notes for suggested software/library.

FEATURES

- 6 pin DIN PS/2 port
- Standard headers for power and data lines
- Power indicator
- < 3mA power consumption
- Designed primarily for Arduino users

PIN FUNCTIONS

The module has a 4 pin 2.54mm pitched header with the following functions.

Pin Label	Function/Operation/Remarks
VCC	+5Vdc. This is the keyboard power. The LED indicator on board will light up when power is applied. Since the module alone draws less than 3mA at 5V, and with keyboards typically being low power, this pin may then be connected to the Saleng Uno/Arduino's 5V pin. Check your specific keyboard and application for exact current consumption.
GND	Ground pin.
DAT	Data pin. Connects to host microcontroller.
CLK	Clock pin. Connects to host microcontroller. When using the recommended library, please connect this to an external interrupt pin. In the Saleng Uno/Saleng BYOA/Saleng Mini 88/Arduino Uno/Nano/Pro Mini/Mega, you may use pins 2 or 3. If the host is the Saleng Mini 644, contact Layad Circuits for instructions. Note that there are other available libraries and this may not be a requirement.

PRECAUTION

Because PS/2 keyboards are typically 5V logic, use level shifters when using 3.3V microcontrollers to safely connect the keyboard to your host.

APPLICATION NOTES

The basic usage and test setup is explained in this note. Using the module, a PS/2 keyboard shall send the equivalent ASCII value of the key which has been pressed. The Arduino shall then display this on screen. The program and library is based on the [PS2Keyboard library by PaulStoffregen](#).

Wiring

The following diagram shows the module used with a Saleng Uno/Arduino Uno:

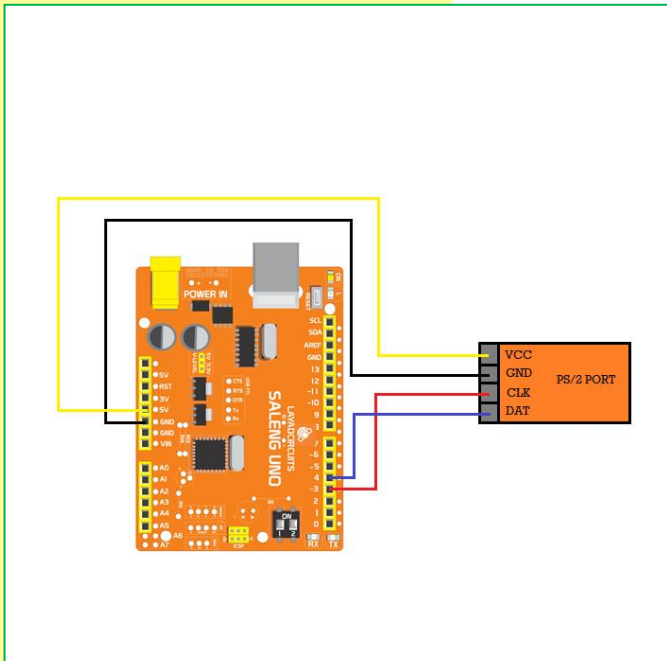

Code

```
#include <PS2Keyboard.h>

const int DataPin = 4;
const int IRQpin = 3;

PS2Keyboard keyboard;

void setup() {
  delay(1000);
  keyboard.begin(DataPin, IRQpin);
  Serial.begin(9600);
  Serial.println("Keyboard Test:");
}

void loop() {
  if (keyboard.available()) {

    // read the next key
    char c = keyboard.read();

    // check for some of the special keys
    if (c == PS2_ENTER) {
      Serial.println();
    } else if (c == PS2_TAB) {
      Serial.print("[Tab]");
    } else if (c == PS2_ESC) {
      Serial.print("[ESC]");
    } else if (c == PS2_PAGEDOWN) {
      Serial.print("[PgDn]");
    } else if (c == PS2_PAGEUP) {
      Serial.print("[PgUp]");
    } else if (c == PS2_LEFTARROW) {
      Serial.print("[Left]");
    } else if (c == PS2_RIGHTARROW) {
      Serial.print("[Right]");
    } else if (c == PS2_UPARROW) {
      Serial.print("[Up]");
    } else if (c == PS2_DOWNARROW) {
      Serial.print("[Down]");
    } else if (c == PS2_DELETE) {
      Serial.print("[Del]");
    } else {
      // otherwise, just print all normal characters
      Serial.print(c);
    }
  }
}
```

The results may be viewed from the Serial Monitor with baud rate set to 9600.

IMPORTANT NOTICE

Layad Circuits Electronics Engineering Supplies & Services (Layad Circuits) reserves the right to make corrections, enhancements, improvements and other changes to its products, services and documentations, and to discontinue any product or service. Buyers or clients should obtain the latest relevant information before placing orders and should verify that such information is current and complete. Additional terms may apply to the use or sale of Layad Circuits products and services.

Reproduction of significant portions of Layad Circuits information in Layad Circuits datasheets or user guides is permissible only if reproduction is without alteration, displays the Layad Circuits logo and is accompanied by all associated warranties, conditions, limitations, and notices. Layad Circuits is not responsible or liable for such reproduced documentation. Information of third parties may be subject to additional restrictions. Resale of Layad Circuits products or services with statements different from or beyond the parameters stated by Layad Circuits for that product or service voids all express and any implied warranties for the associated Layad Circuits product or service. Layad Circuits is not responsible or liable for any such statements.

Buyers and others who are developing systems that incorporate Layad Circuits products (collectively, "Designers") understand and agree that Designers remain responsible for using their independent analysis, evaluation and judgment in designing their applications and that Designers have full and exclusive responsibility to assure the safety of Designers' applications and compliance of their applications (and of all Layad Circuits products used in or for Designers' applications) with all applicable regulations, laws and other applicable requirements. Designer represents that, with respect to their applications, Designer has all the necessary expertise to create and implement safeguards that (1) anticipate dangerous consequences of failures, (2) monitor failures and their consequences, and (3) lessen the likelihood of failures that might cause harm and take appropriate actions. Designer agrees that prior to using or distributing any applications that include Layad Circuits products, Designer will thoroughly test such applications and the functionality of such Layad Circuits products as used in such applications. Layad Circuits' provision of technical, application or other design advice, quality characterization, reliability data or other services or information, including, but not limited to, reference designs and materials relating to evaluation modules, (collectively, "Layad Circuits Resources") are intended to assist designers who are developing applications that incorporate Layad Circuits products; by downloading, accessing or using Layad Circuits Resources in any way, Designer (individually or, if Designer is acting on behalf of a company, Designer's company) agrees to use any particular Layad Circuits Resource solely for this purpose and subject to the terms of this Notice.

Layad Circuits' provision of Layad Circuits Resources does not expand or otherwise alter Layad Circuits' applicable published warranties or warranty disclaimers for Layad Circuits products, and no additional obligations or liabilities arise from Layad Circuits providing such Layad Circuits Resources.

Layad Circuits reserves the right to make corrections, enhancements, improvements and other changes to its Layad Circuits Resources. Layad Circuits has not conducted any testing other than that specifically described in the published documentation for a particular Layad Circuits Resource.

NO OTHER LICENSE, EXPRESS OR IMPLIED, BY ESTOPPEL OR OTHERWISE TO ANY OTHER LAYAD CIRCUITS INTELLECTUAL PROPERTY RIGHT, AND NO LICENSE TO ANY TECHNOLOGY OR INTELLECTUAL PROPERTY RIGHT OF LAYAD CIRCUITS OR ANY THIRD PARTY IS GRANTED HEREIN, including but not limited to any patent right, copyright, mask work right, or other intellectual property right relating to any combination, machine, or process in which Layad Circuits products or services are used. Information regarding or referencing third-party products or services does not constitute a license to use such products or services, or a warranty or endorsement thereof. Use of Layad Circuits Resources may require a license from a third party under the patents or other intellectual property of the third party, or a license from Layad Circuits under the patents or other intellectual property of Layad Circuits. LAYAD CIRCUITS RESOURCES ARE PROVIDED "AS IS" AND WITH ALL FAULTS. LAYAD CIRCUITS DISCLAIMS ALL OTHER WARRANTIES OR REPRESENTATIONS, EXPRESS OR IMPLIED, REGARDING RESOURCES OR USE THEREOF, INCLUDING BUT NOT LIMITED TO ACCURACY OR COMPLETENESS, TITLE, ANY EPIDEMIC FAILURE WARRANTY AND ANY IMPLIED WARRANTIES OF MERCHANTABILITY, FITNESS FOR A PARTICULAR PURPOSE, AND NON-INFRINGEMENT OF ANY THIRD PARTY INTELLECTUAL PROPERTY RIGHTS. LAYAD CIRCUITS SHALL NOT BE LIABLE FOR AND SHALL NOT DEFEND OR INDEMNIFY DESIGNER AGAINST ANY CLAIM, INCLUDING BUT NOT LIMITED TO ANY INFRINGEMENT CLAIM THAT RELATES TO OR IS BASED ON ANY COMBINATION OF PRODUCTS EVEN IF DESCRIBED IN LAYAD CIRCUITS RESOURCES OR OTHERWISE. IN NO EVENT SHALL LAYAD CIRCUITS BE LIABLE FOR ANY ACTUAL, DIRECT, SPECIAL, COLLATERAL, INDIRECT, PUNITIVE, INCIDENTAL, CONSEQUENTIAL OR EXEMPLARY DAMAGES IN CONNECTION WITH OR ARISING OUT OF LAYAD CIRCUITS RESOURCES OR USE THEREOF, AND REGARDLESS OF WHETHER LAYAD CIRCUITS HAS BEEN ADVISED OF THE POSSIBILITY OF SUCH DAMAGES. Unless Layad Circuits has explicitly designated an individual product as meeting the requirements of a particular industry standard, Layad Circuits is not responsible for any failure to meet such industry standard requirements. Where Layad Circuits specifically promotes products as facilitating functional safety or as compliant with industry functional safety standards, such products are intended to help enable customers to design and create their own applications that meet applicable functional safety standards and requirements. Using products in an application does not by itself establish any safety features in the application. Designers must ensure compliance with safety-related requirements and standards applicable to their applications. Designer may NOT use any Layad Circuits products in life-critical applications. Life-critical medical equipment is medical equipment where failure of such equipment would cause serious bodily injury or death (e.g., life support, pacemakers, defibrillators, heart pumps, neurostimulators, and implantables). Designers agree that it has the necessary expertise to select the product with the appropriate qualification designation for their applications and that proper product selection is at Designers' own risk. Designers are solely responsible for compliance with all legal and regulatory requirements in connection with such selection. Designer will fully indemnify Layad Circuits and its representatives against any damages, costs, losses, and/or liabilities arising out of Designer's noncompliance with the terms and provisions of this Notice.

Revision: v1.0 / 19 July 2019 / D.M.YANZON/C.D.MALECDAN

www.layadcircuits.com

Layad Circuits Electronics Engineering Supplies & Services, B314 Lopez Bldg., Session Rd. cor. Assumption Rd., Baguio City, Philippines
General inquiries: info@layadcircuits.com Sales: sales@layadcircuits.com FB: facebook.com/layadcircuits Mobile: +639164428565

An IMPORTANT NOTICE: at the end of this guide addresses availability, warranty, changes, use in safety-critical applications, intellectual property matters and other important disclaimers.