

Overview:

This is an easy to build automatic and contactless alcohol dispenser kit.

- This kit does NOT require soldering.
- NO MCU/Arduino required!
- This DIY kit is expected to be manually assembled basing on the circuit diagram provided.

Unlike other similar kits, the circuit here is properly designed with the correct components included and with ease of assembly in mind.

User needs to add container for the alcohol/liquid and provide power source.

The kit should be powered from a microUSB charger ideally rated for 2.1A. Some chargers rated 1A may not have sufficient power to drive the pump. Alternatively, the device may be powered from other sources such as a power bank.

The content of the kit are:

- 1x mini Pump
- 1x 30cm hose for the pump
- 1x mini breadboard
- 1x Layad Circuits IR sensor module
- 1x MOSFET Transistor,
N channel
- 1x 10K resistor (pull down for Gate circuit)
- 1x 1N4007 or 1N4001 (flyback protection)

KIT004 - DIY Automatic Contactless Alcohol Dispenser Kit User Guide

1x terminal block (for pump terminals)

1x 30cm solid wire for breadboard connections

1x microUSB adapter with headers already soldered

Demo: youtu.be/Tbv0YC0MUkg

NOTES on orders: - Certain kit parts may have different colors or slightly different form. E.g. wire, breadboard and terminal block may have a different color - The hose may come to you already inserted on the pump outlet as other users may find it difficult to insert - Unlike similar kits, we test every single pump with the hose in distilled water. If the hose or pump reaches you with small amount of water in them, treat them as normal.

NOTES on Assembly/Operation: - Basic electronics knowledge may be required for the assembly of this kit. Ambient IR sources such as sunlight may affect the current threshold, you may adjust this using the onboard potentiometer on the sensor board. - Avoid use in direct sunlight - If your pump fails to perform, check the following: --- ensure a power source that can deliver continuous currents of up to 1A. A 2A or higher charger is recommended. --- ensure the pump is submerged in the liquid - As you assemble, check for the correct orientation and polarities. The diode, microUSB adapter, sensor, and transistor should be connected strictly following the circuit. - keep the diode as close as possible to the pump terminals - The breadboard is meant to help you connect the circuit without soldering, should you wish to solder, a double sided PCB matrix board is recommended. - Since the resistor and/or diode may have smaller leads than the breadboard holes, you may want to either bend the legs over and twist for a thicker connection point or you could insert solid wire on the same hole as that of the resistor/diodes lead for better connectivity. - The circuit is designed to work with the specific components provided in this kit and may or may not work with other parts. We don't mind you copying the design, just be careful when using other parts :) But of course, we would be happy to process your orders.

SETTING UP and TROUBLESHOOTING GUIDE

1 Double check that all connections follow the wiring diagram

2

before power up, check there is NO connection (shorts) between Vbus and GND using your DMM/VOM in ohmmeter mode

Warning! If a short is detected, fix it first before powering up the circuit.

3

Calibrate: Adjust the sensor's potentiometer both ways until the built in LED is ON. Then slowly rotate the potentiometer until the LED just starts to turn OFF. Wave your hand in front of the sensor and you should see the LED turn on. Remove your hand turns it back OFF.

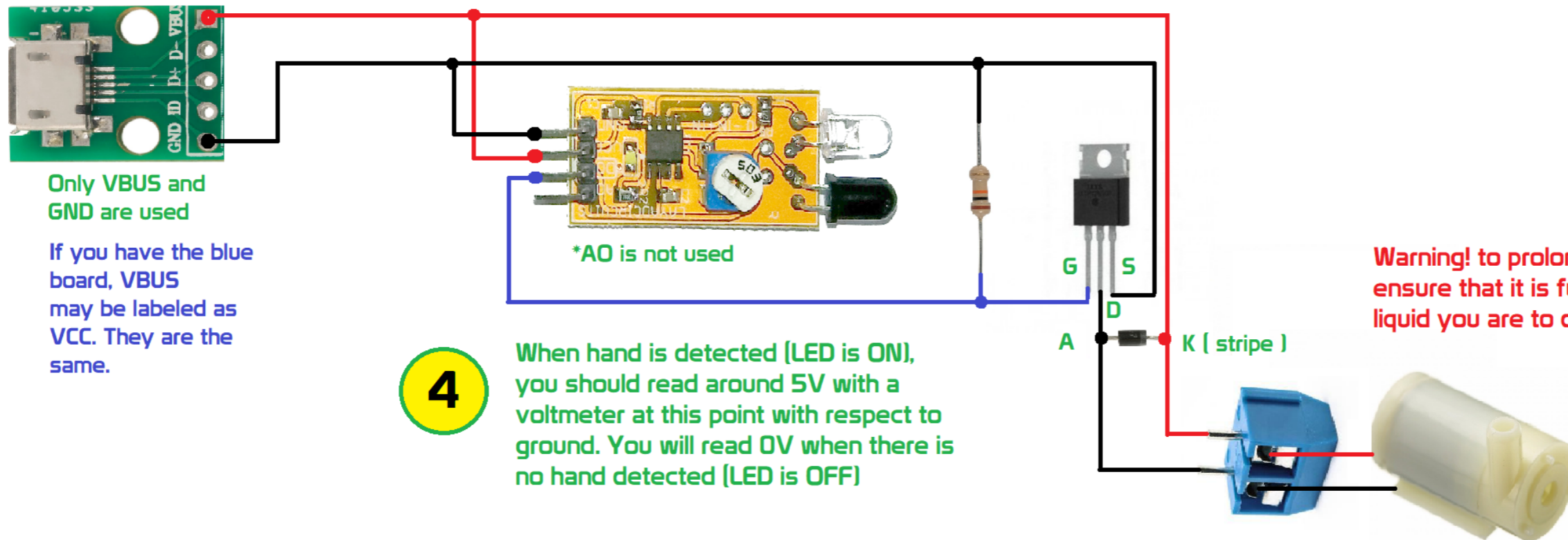

4

When hand is detected (LED is ON), you should read around 5V with a voltmeter at this point with respect to ground. You will read 0V when there is no hand detected (LED is OFF)

5

When hand is detected, you should measure around 5V across these terminals with a voltmeter. You will read 0V when hand is not pumping. If you do not get these, check the connectivity of the terminal block and pump.

